



CLEVELAND
MIXER
EST. 1940

CLEVELAND MIXER
4 Heritage Park Rd.
Clinton, CT 06413

P: (800) 243-1188
P: (860) 669-1199
F: (860) 669-7491

info@clevelandmixer.com

XTRA-FLO LITE

IBC TOTE TANK MIXER SERIES

- » DESIGNED for IBC tote tanks from 275 to 550 gallons.
- » BROAD RANGE of configurations to meet specific process goals.
- » STRONG, CORROSION RESISTANT materials protect against bending and stress in a variety of applications.

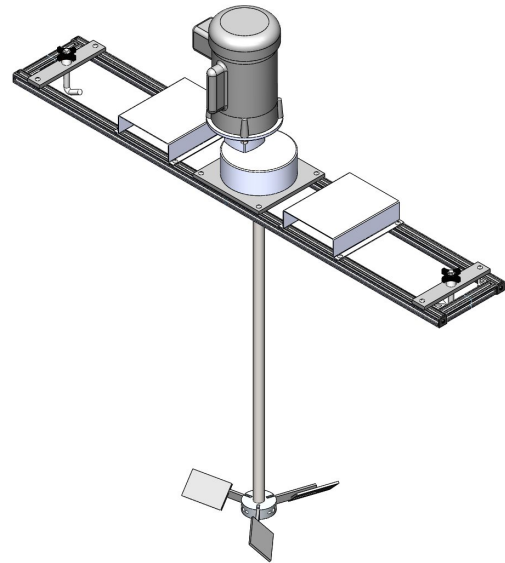

HIGHLY ENGINEERED TOTE TANK MIXERS

Xtra-Flo Lite mixers are optimally designed for mixing and blending in 275 to 550 gallon tote tanks. Engineered to be durable, light weight, and modular, the Xtra-Flo Lite series accommodates a wide range of viscosities and almost any brand of IBC tote tank. Premium materials provide support against bending and torsional loads. They are easy to install and remove, and the same frame and mounting can be used with multiple tank volumes.

Built around a high strength, corrosion resistant, alloy frame, these mixers can be configured with direct drive to agitate low viscosity fluids or with a gear drive and large diameter, collapsible impellers to blend higher viscosities.

CUSTOMIZED TO MEET YOUR PROCESS GOALS

The product range includes ½ HP direct drive mixers with standard propellers to 5 HP gear drive mixers. All electric powered models feature TEFC, industrial grade motors by Baldor. Single and three phase motors are available from stock. All single phase equipped models come with a 10' line cord, 3 prong plug and switch. All wetted materials are 316SS/L. Impeller shaft length is 32". Air powered mixers include a needle valve for speed adjustment. Filter and lubricator sets are available as an option. All wetted materials are 316SS/L. Impeller shaft length is 32".

RAPID DELIVERY

Most standard models are available immediately, and ship within 24 hours.



**CLEVELAND
MIXER**
EST. 1940

CLEVELAND MIXER
4 Heritage Park Rd.
Clinton, CT 06413

P: (800) 243-1188
P: (860) 669-1199
F: (860) 669-7491

info@clevelandmixer.com

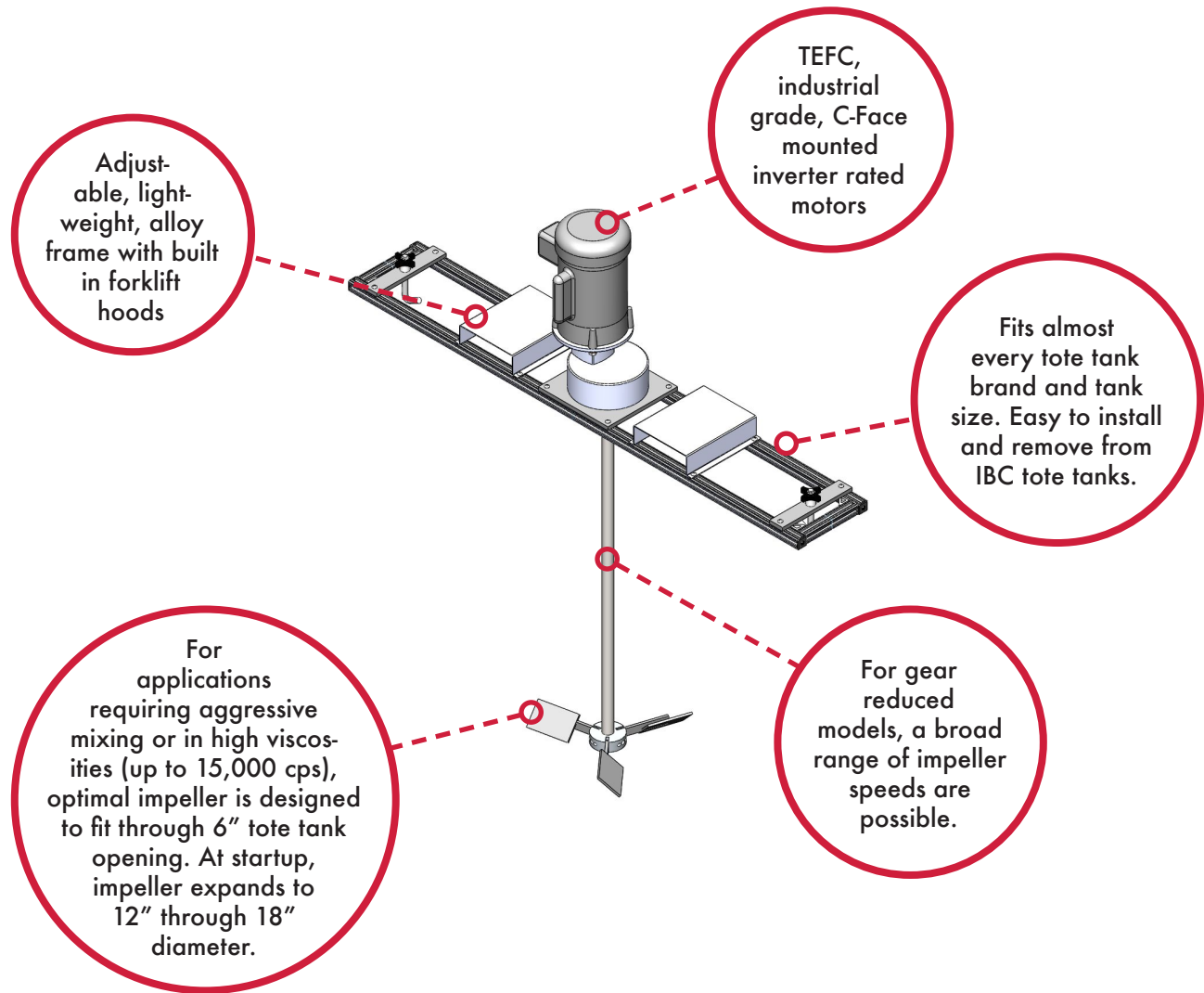

Why choose Cleveland Mixer for all your fluid process applications?

- » APPLICATION ENGINEERING—your process goals are our top priority
- » DESIGN FLEXIBILITY—let our engineering team create solutions for you
- » INDUSTRY LEADING DURABILITY and 3 year guarantee