

# FIXED ENTRY PORTABLE MIXERS

## Installation, Maintenance & Operating Instructions

CLOSED TANK MODELS: FRG-C, SFRG, FRAG-C, FRGM, FRGS, FRH-C, FRAH-C  
OPEN TANK MODELS: FRG, FRAG, FRH, FRA

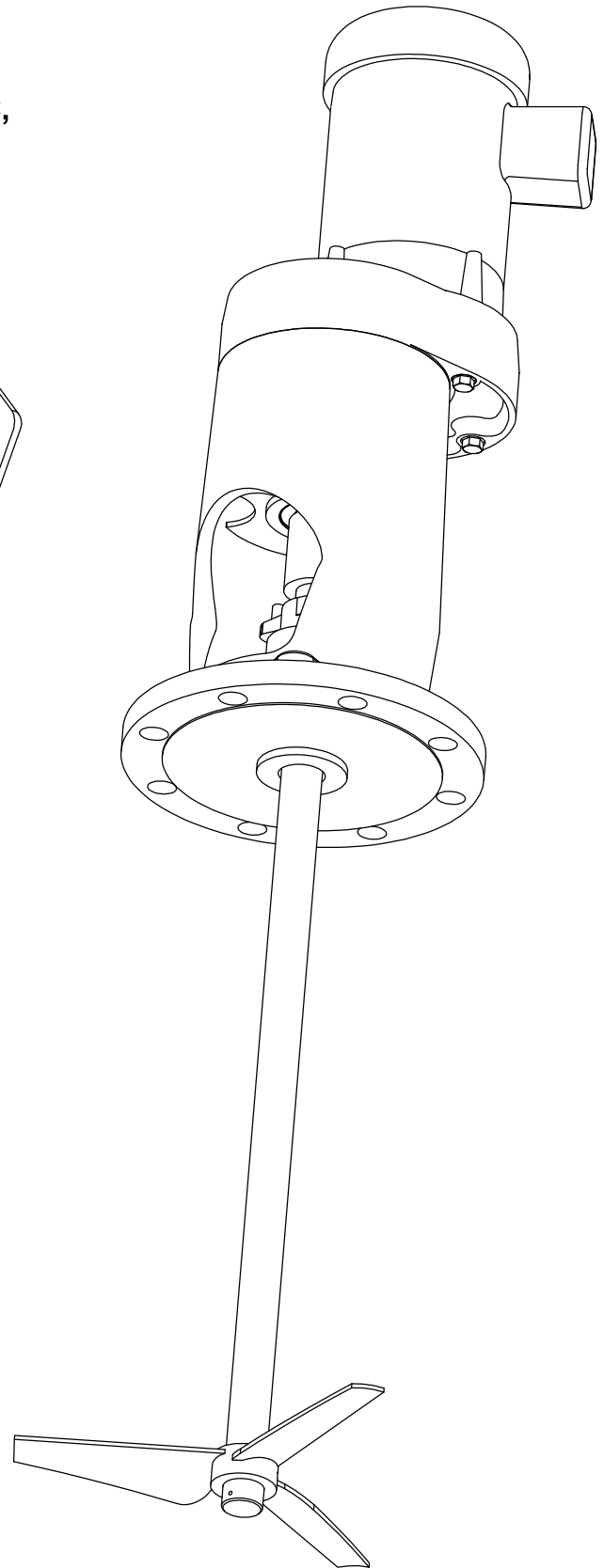
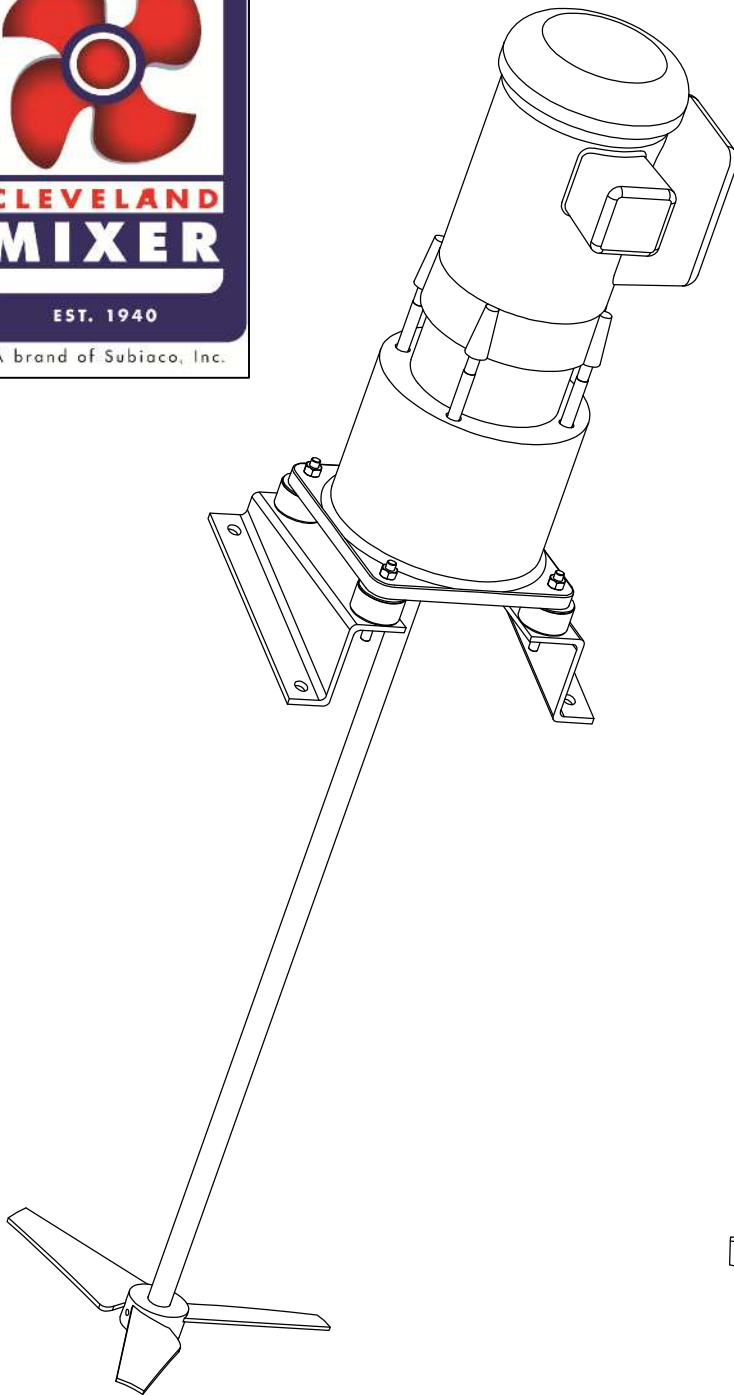

# TABLE OF CONTENTS

## Installation, O&M

|                             |     |
|-----------------------------|-----|
| Uncrating, handling         | 1   |
| Lifting & Moving            | 1   |
| Mounting                    | 1   |
| Impeller, Prop Installation | 2   |
| Air Motor Info              | 3   |
| Electric Motor Info         | 3,4 |
| Bolt Torque Chart - Thrust  | 5   |
| Bolt Torque Chart - Rigid   | 6   |
| Side Entry Shut-Off Device  | 7   |
| Lip Seals                   | 8   |
| Stuffing Boxes              | 9   |
| Mechanical Seals            | 10  |
| Couplings                   | 11  |
| Mixer Positioning           | 12  |
| Deactivation & Storage      | 13  |
| Trouble Shooting            | 14  |

## Parts Breakdown

|                               |    |
|-------------------------------|----|
| FRG Open Tank, Gear Driven    | 15 |
| FRG Closed Tank, Gear Driven  | 16 |
| FRH Open Tank, Direct Drive   | 17 |
| FRH Closed Tank, Direct Drive | 18 |
| Drives, Arbors, Stuffing Box  | 19 |
| Parts List                    | 20 |
| Parts List                    | 21 |

# Installation

All mixers should be installed by a professional. Any attempt to lift, wire, mount or assemble a mixer by an unqualified party can result in serious injury or death.

## Handling

Lift the mixer with care. The drive unit, impeller and shaft might be packed separately. Never lift the mixer by the motor or output shaft. If the mixer is fully assembled, make sure to adequately support the output shaft. Make sure to check for hardware, owner's manual and other components that might be inside the packing before discarding the packaging.

## Mounting

Install the mixer at the recommended location for optimum results (see page 12). Follow the torque value chart on pages 5-6 to secure all fasteners. The mounting surface for the mixer should be level and rigid. Never secure a mixer to a flexible material such as fiberglass. If the mounting surface or structure is not rigid enough to handle the forces put out by the mixer, it will cause excessive runout which can damage the mixer. For closed tank models, bolt the mixer with the stool assembly opening so it is accessible for servicing. If the mixer is equipped with a stuffing box, make sure to lubricate the stuffing box before operating the mixer. If the mixer is equipped with a mechanical seal, make sure to follow the manufactures operating instructions supplied with the seal. Double check all in-tank fasteners (such as the set screws) that secure the impeller to the shaft. Double check that the impellers (or propellers) were installed correctly. Most impellers and propellers have a top and bottom which should be appropriately marked.

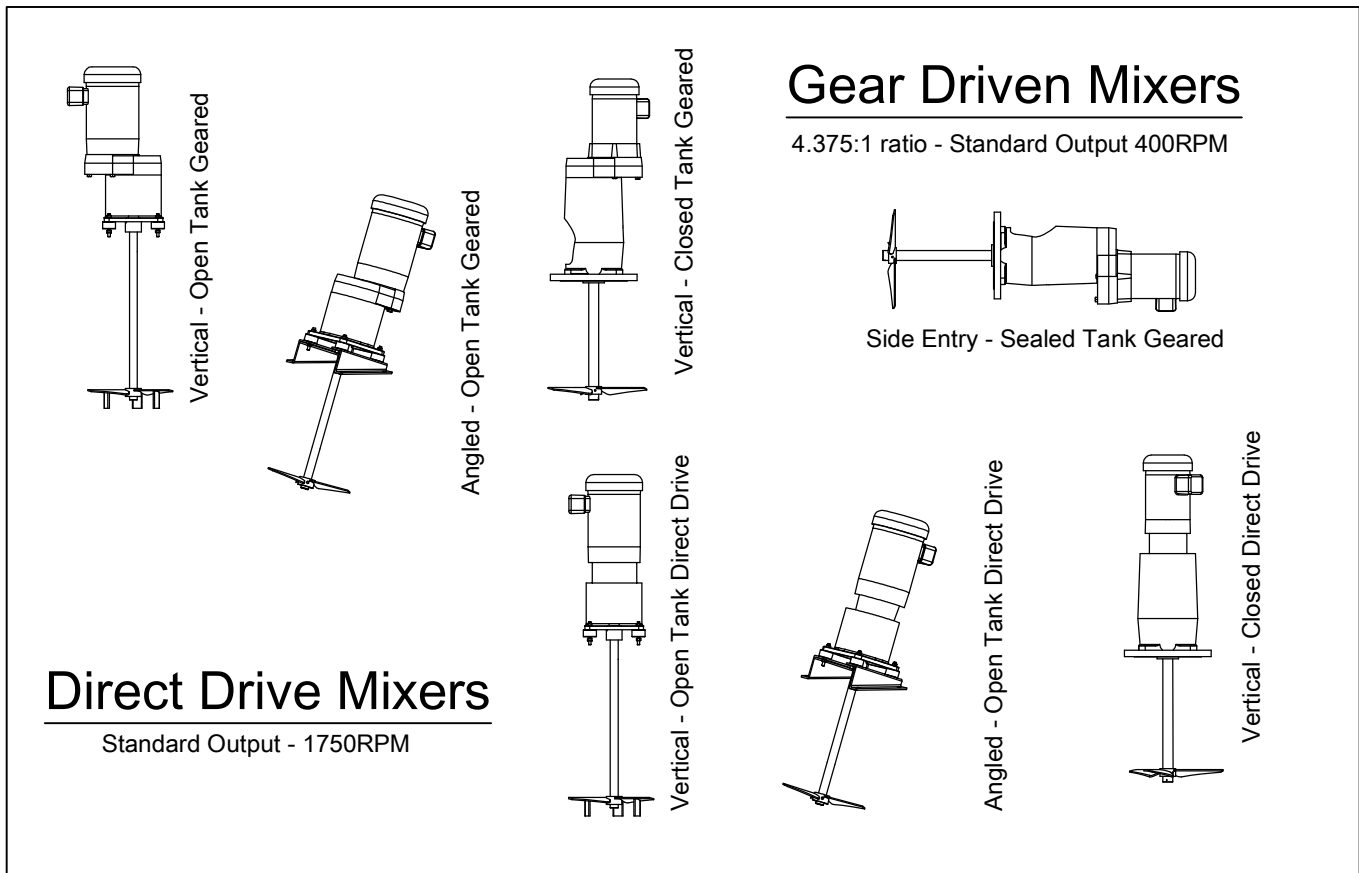

# Installation

## Hydrofoil Impeller and Propeller Assembly

Most Cleveland Mixer portable mixers are supplied with an XTF-3 impeller or a marine style 3 bladed propeller. Standard impellers and propellers are designed to rotate clockwise and pump down or away from the mixer. Some applications might require the XTF-3 impeller to be supplied with stabilizer fins which will be located on the driving side of the blades. Make sure to mount the blades with the stabilizer fins pointed down. If your mixer has multiple impellers and only 1 impeller has fins, the impeller with the fins will be the lower impeller. See diagram below for blade positioning. The spacing or positioning of the impellers is significant with respect to the stability, fluid regime and horsepower draw. Generally, the minimum spacing is two impeller diameters with an optimum of four impeller diameters apart.

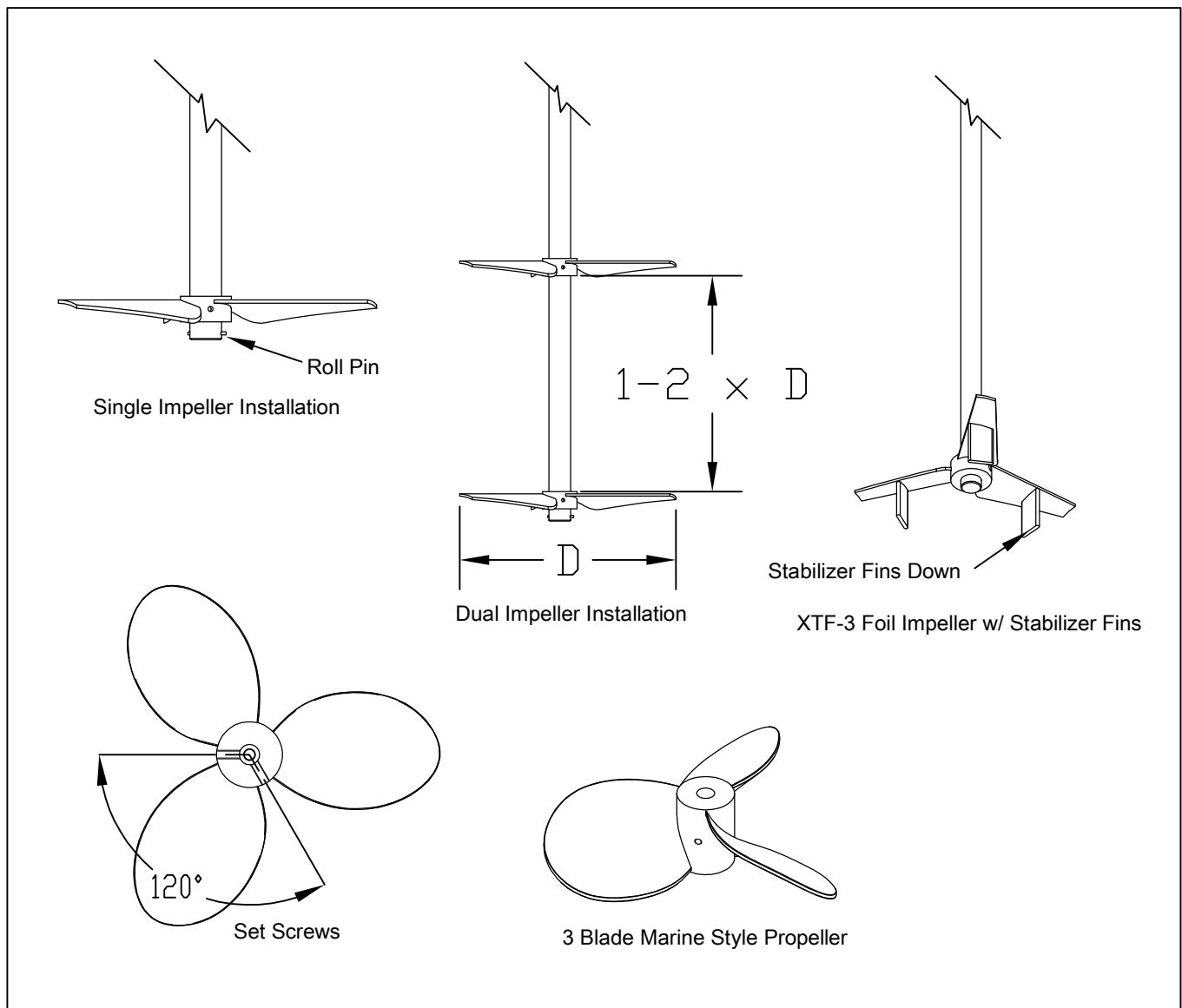

# Installation

## Air Power Supply

Your air motor will come with manufacturers operating instructions. Make sure to refer to these instructions for specific information regarding air pressure and operating conditions for your air motor. Make sure that the input line is installed on the correct side of the air motor for your impeller or propeller to rotate in the correct direction. Standard propellers and impellers should rotate clockwise. Gear drives reverse the direction of the output. If you run your airline into the motor so that the motor's output shaft spins clockwise, the mixer's output will be counter clockwise. Be sure to reverse the input so that the mixer output rotates clockwise. Cleveland Mixer recommends installing a moisture trap and filter in the air line ahead of the motor. Using a filter will help to prevent contaminants and moisture from effecting the performance of your air motor. A needle valve or speed regulator will allow you to control the mixing RPM's. You will need to lubricate your air motor with air tool oil as specified by the mfg's O&M.

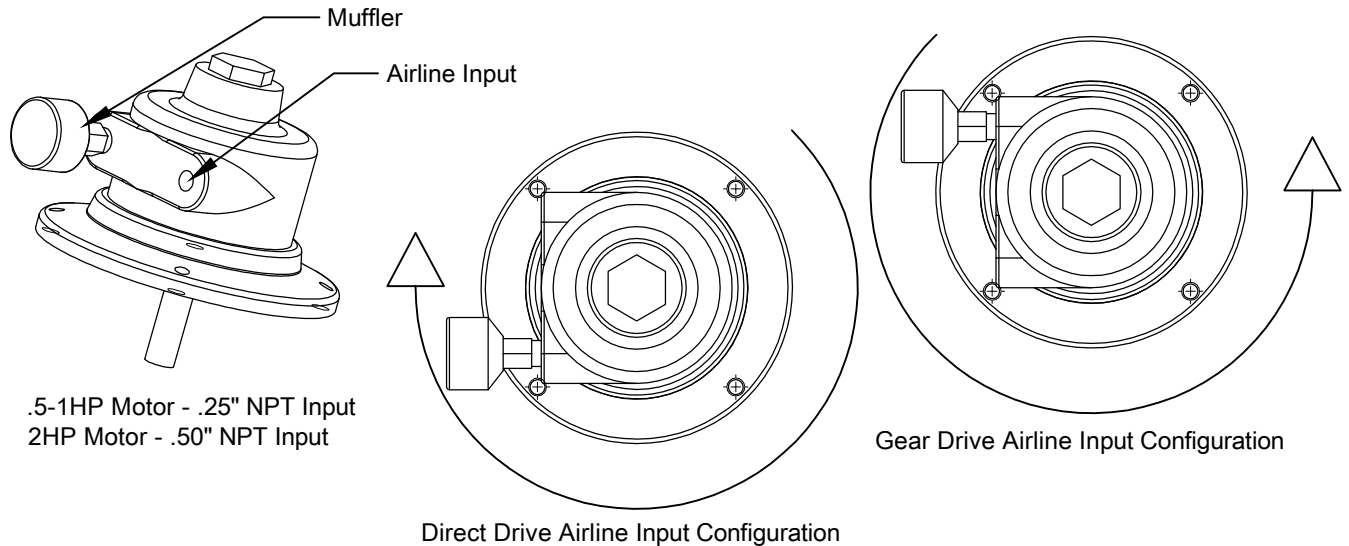

## Electric Power Supply

All electrical wiring should be handled by a professional. Any attempt to wire an electrical motor by an unqualified party can result in damage to the equipment, serious injury or death. Be certain the mixer is wired to run with the impeller rotating in the correct direction. Standard design is clockwise output. Gear drives reverse rotation. If your motor is wired to run clockwise, the output will be counter clockwise and that is not correct. The motor will need to be wired to run counter clockwise on all gear driven mixers. The motor will be wired to run clockwise for all standard direct drive mixers. A copy of the motor manufacturers operating instructions will be supplied with your mixer. Please read and follow these instructions carefully.

Please contact the factory for information about mixers that can be supplied with cord & plug assemblies, variable frequency drives and speed controllers.

# Installation

## Electric Power Supply

Cleveland Mixer mixers are supplied with motors manufactured by nationally known sources. Under normal operating conditions, within specified temperatures, proper installation and maintenance, these motors will deliver their rated output.

If the mixer will be operating in a particularly harsh environment (e.g. extreme temperatures, high levels of dust, etc.). Please contact Cleveland Mixer before operating your mixer. Standard motors are fan cooled which may not be the right motor for your application.

To get the best performance and a long service life from your electric motor, be sure there is plenty of air circulation and a minimum of obstructions. On fan cooled motors, be sure not to choke off the suction inlets. Also be sure to check the allowable temperature, amp draw, horsepower and voltage indicated on the motor plate.

Always consult Cleveland Mixer before making changes to your process. Your mixer was designed to run in a process. Changes to this process can be detrimental to the proper operation of your mixer.

To avoid damage to the motor during temporary overloads, jams, etc., be sure overload protection is provided. Starter overload heater elements can be sized from the full load current of the motor (as shown on the nameplate).

Before the electric motor is put into operation, check the gear drive nameplate to be sure the output shaft rotation is correct. Standard output rotation is clockwise (when looking down from the top).

To reverse the rotation of standard 3 phase electric motors, simply switch any two power leads. Check the manufacturers literature supplied with your mixer for more information.

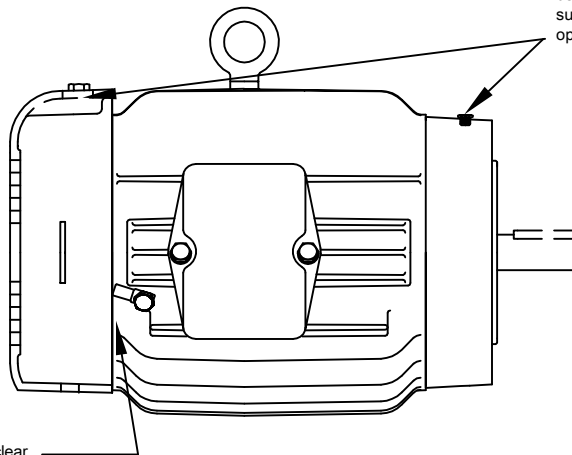
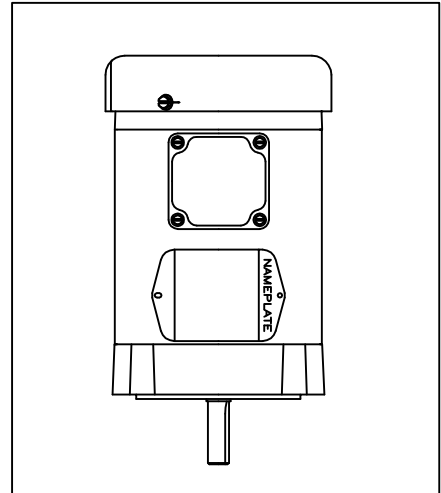

If your motor has grease fittings for the upper and lower bearings, please make sure to add grease to the bearings as suggested by the manufacturer. This will help to extend the operation life of the bearings.

TEFC motors ( totally enclosed, fan cooled)  
make sure to keep the suction inlets free and clear.

# IMPELLERS & SHAFTS

## TORQUE VALUES FOR THRUST BOLTS

| BOLT SIZE         | ALL MATERIALS |        |
|-------------------|---------------|--------|
|                   | FOOT POUNDS   | NUMBER |
| 1/2 - 13          | 50            | 68     |
| 5/8 - 11          | 90            | 122    |
| 3/4 - 10          | 160           | 217    |
| 7/8 - 9           | 140           | 190    |
| 1 - 8             | 220           | 298    |
| 1 - 1/8 - 7       | 300           | 407    |
| 1 - 1/4 - 7       | 420           | 570    |
| 1 - 3/8 - 6       | 556           | 754    |
| 1 - 1/2 - 6       | 740           | 1003   |
| 1 - 3/4 - 5       | 825           | 1118   |
| 2 - 4 - 1/2       | 1125          | 1525   |
| 2 - 1/4 - 4 - 1/2 | 1725          | 2338   |
| 2 - 1/2 - 4       | 2300          | 3117   |

\* Lubricate bolt before installation. Torque each bolt to the appropriate value as shown above.

NOTE: The bolt torques shown here will develop a fastener pre load of 80 % of the fastener's minimum yield.

COUPLING BOLTS - LOW SPEED SHAFT: At least Grade 5. The torque required may be found using the Grade 5 chart and reading across from the bolt diameter to be used. If stainless bolts are used, proceed with the proper stainless steel chart. Any looseness in these bolts causes the coupling to apply a shear load on the bolt and a high impact tensile load or shock load.

This shock load and shear load can cause the bolts to snap, the holes to elongate or the coupling to fail to keep the shaft running straight which can have numerous disastrous effects on the mixer.

1. Tighten all fasteners to the values shown unless specifically instructed to do otherwise.
2. Lubricate all fasteners at assembly with grease, oil or anti-seize material.
3. If fasteners cannot be lubricated, multiply table values by 1.33
4. Loose bolts can cause severe damage. It is very important to check all fasteners on a regular basis to make sure they haven't come loose. \*\*\*\*
5. If your process material is corrosive or sanitary, check the wetted hardware to make sure it is the correct grade before assembly.

# IMPELLERS & SHAFTS

## TORQUE VALUES FOR RIGID SHAFT COUPLINGS

| BOLT SIZE   | CARBON STEEL |     |         |      | Stainless Steel, Alloy 20, Monel, Hastelloy C |        |
|-------------|--------------|-----|---------|------|---|--------|
|             | Grade 2      |     | Grade 5 |      |   |        |
|             | FT-LB        | Nm  | FT-LB   | Nm   | FOOT-LBS                                      | NUMBER |
| 3/8 - 16    | 15           | 20  | 23      | 30   | 15  | 21     |
| 1/2 - 13    | 38           | 51  | 56      | 77   | 37  | 50     |
| 9/16 - 12   | 50           | 68  | 83      | 112  | 54  | 72     |
| 5/8 - 11    | 68           | 92  | 113     | 152  | 74  | 101    |
| 3/4 - 10    | 120          | 163 | 200     | 271  | 131   | 178    |
| 7/8 - 9     | 105          | 143 | 296     | 401  | 212   | 287    |
| 1 - 8       | 165          | 224 | 443     | 601  | 318   | 432    |
| 1 - 1/8 - 7 | 225          | 305 | 596     | 808  | 450   | 610    |
| 1 - 1/4 - 7 | 315          | 428 | 840     | 1139 | 636   | 862    |
| 1 - 3/8 - 6 | 417          | 566 | 1003    | 1495 | 834   | 1130   |
| 1 - 1/2 - 6 | 555          | 752 | 1463    | 1983 | 1470  | 1500   |

\* Lubricate bolt before installation. Torque each bolt to the appropriate value as shown above.

NOTE: The bolt torques shown here will develop a fastener pre load of 80% of the fastener's minimum yield.

COUPLING BOLTS - LOW SPEED SHAFT: At least Grade 5. The torque required may be found using the Grade 5 chart and reading across from the bolt diameter to be used. If stainless bolts are used, proceed with the proper stainless steel chart. Any looseness in these bolts causes the coupling to apply a shear load on the bolt and a high impact tensile load or shock load.

This shock load and shear load can cause the bolts to snap, the holes to elongate or the coupling to fail to keep the shaft running straight which can have numerous disastrous effects on the mixer.

1. Tighten all fasteners to the values shown unless specifically instructed to do otherwise.
2. Lubricate all fasteners at assembly with grease, oil or anti-seize material.
3. If fasteners cannot be lubricated, multiply table values by 1.33
4. Loose bolts can cause severe damage. It is very important to check all fasteners on a regular basis to make sure they haven't come loose. \*\*\*\*
5. If your process material is corrosive or sanitary, check the wetted hardware to make sure it is the correct grade before assembly.



# STUFFING BOX/MECHANICAL SEAL - INSTALLATION

## SIDE ENTRY SHUT OFF DEVICE

The side entry shut off device is located inside the tank and is intended to assist the maintenance personnel when performing maintenance on the packing gland. It consists of a piece of UHMW-PE (ultra high molecular weight polyethylene) or PTFE (Teflon) with a clamp collar backer and should be set slightly off the face (about 1/4") of the mounting flange. When it comes time to engage the shut-off device, you must release the fixing element bolt at the top of the shaft. Once the bolt is out, remove the fixing element. You will then have to remove the snap ring from its groove at the top of the hollow quill. Pull the shaft outward until you can feel the shut-off press against the tank flange. You will need to clamp the shaft in place to prevent it from sliding back out. This shut-off device is to aid for emergency packing gland maintenance it should not be used as an air tight seal. When possible, always drain the tank before disengaging any fasteners on the mixer.

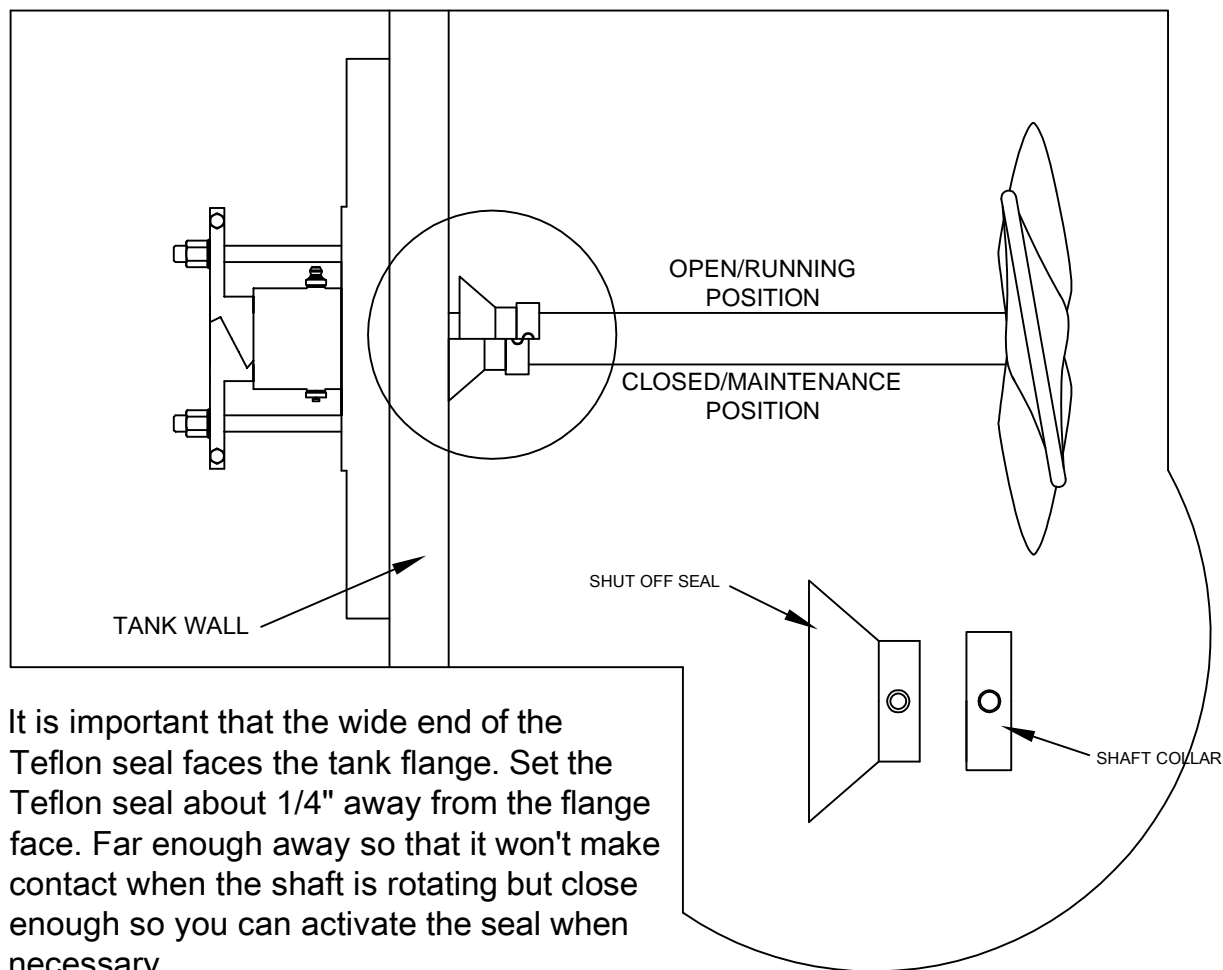

# LIP SEAL INFORMATION

The Clipper design features an integrally molded rubber fiber outer case and an elastomeric seal lip.

The unique, nonmetallic construction will not rust or corrode and forms a gasket-type seal between the equipment housing and the seal outside diameter. Clipper Split Seals are known for being the easiest split seal to install because they do not require a cover plate to keep them in the housing. The robust, composite OD provides the best retention of any split seal on the market. Replacing failed seals in the field saves on downtime and lost production. To change out the seals in the field, simply remove the coil tensioner, separate the split seal and peel the seal off from the shaft. Follow the same procedure in reverse to reinstall.

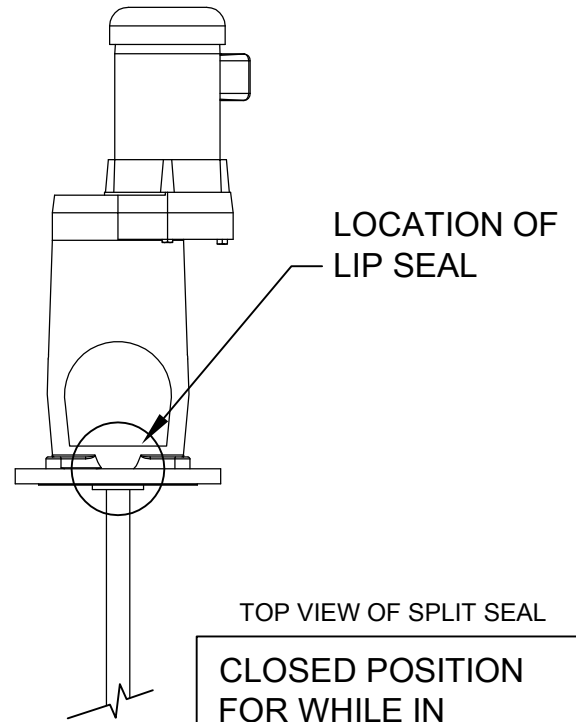

TOP VIEW OF SPLIT SEAL

CLOSED POSITION FOR WHILE IN OPERATION

COIL TENSIONER

OPEN POSITION; REMOVAL, MAINTENANCE

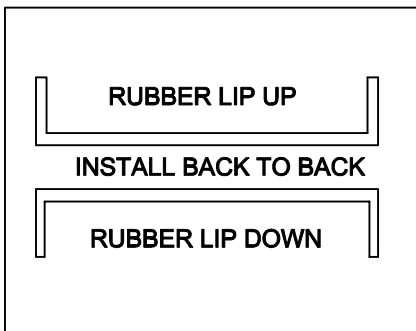
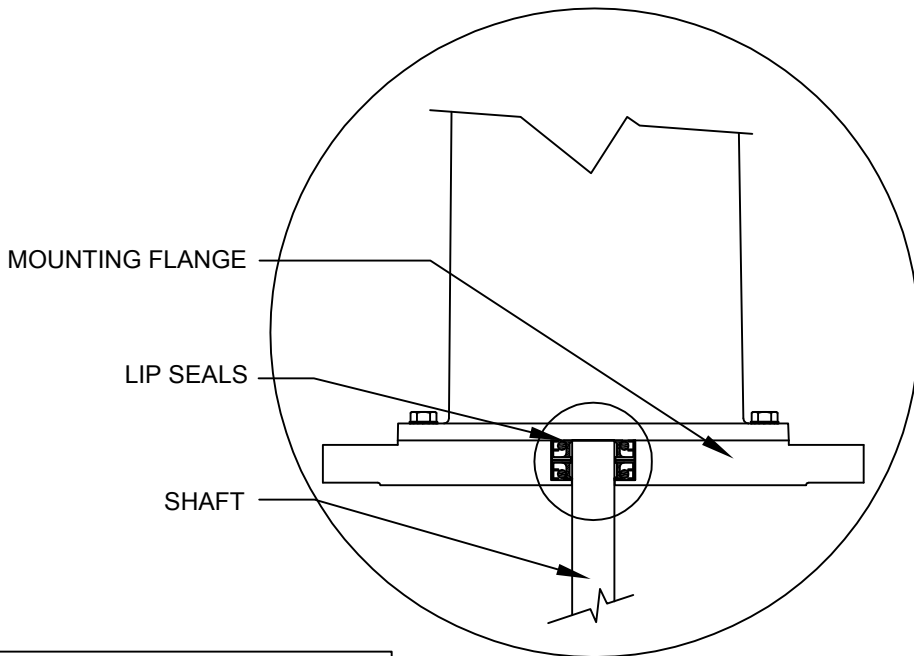
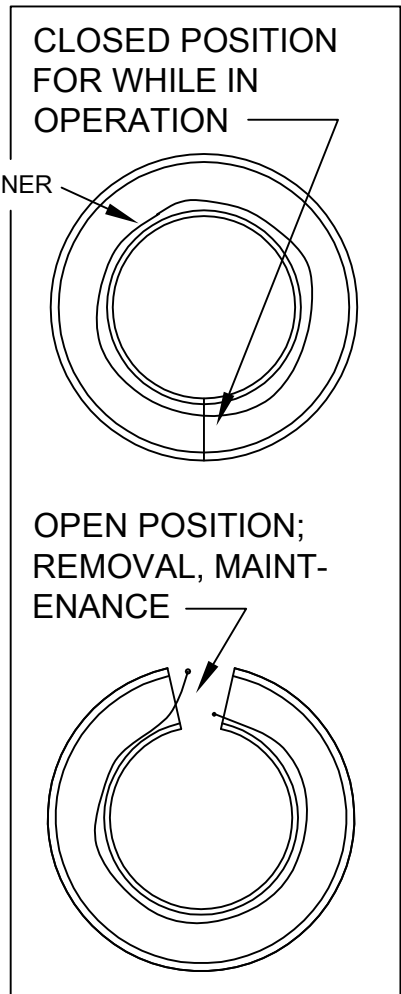

# STUFFING BOX/MECHANICAL SEAL - INSTALLATION

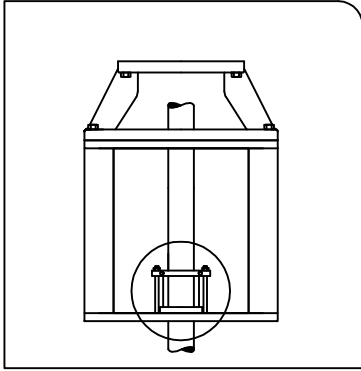

LOW PRESSURE STUFFING BOX

Packing should always be inserted as individual rings, never wound in a spiral. Lubricate each ring generously with grease on the top and bottom surfaces: this will help minimize run-in time. Typically the set up for a high pressure stuffing box is 3 packing rings on the bottom then the lantern ring, 4 packing rings on top and then the split follower. For a low pressure stuffing box - 2 pieces of packing with the split follower on top.

It is important to keep the Stuffing Box properly lubricated in order for it to work properly. If the lantern ring and packing dry out, friction from the spinning shaft will burn up the packing and damage the shaft. The sealing properties of the packing will also not work if they are running dry. Lubricate the stuffing box through the grease fittings with a grease gun. Once the rings are properly greased, tighten down the follower finger tight only. Turn the mixer on and run at atmospheric pressure for 5-10 minutes. Then turn the mixer off and tighten down on the follower 1/2 turn of the follower bolts. The follower should always be pulled down uniformly and never more than 1/2 turn on the bolts at one time.

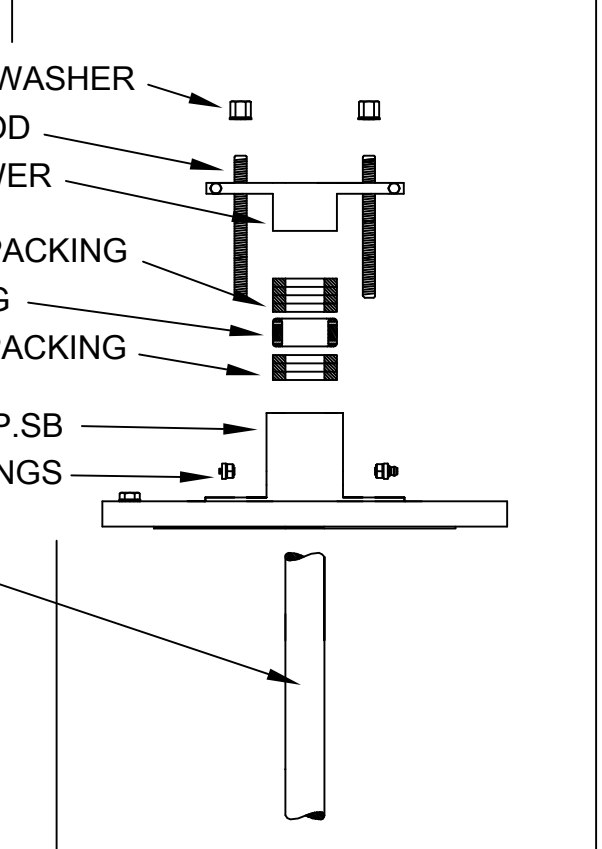
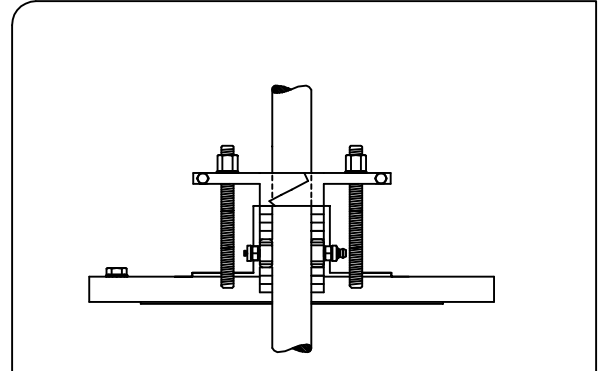

- BOLT & LOCK WASHER
- THREADED ROD
- SPLIT FOLLOWER
- 4 PIECES OF PACKING
- LANTERN RING
- 3 PIECES OF PACKING
- FLANGE W/ H.P.SB
- GREASE FITTINGS
- SHAFT

HIGH PRESSURE STUFFING BOX

With the mixer running, slowly pressurize the vessel to its most extreme operating pressure. At the same time, tighten slowly on the follower bolts to hold pressure as it rises. Never tighten more than 1/2 turn at one time, and let the mixer run at least five minutes between each tightening.

# Stuffing Box / Mechanical Seals

The total amount of tightening will vary, depending on the degree of tamping, the operating pressure and the density of the packing. Hard packing should seal in about one full turn of the bolts. Softer packing may take two or more turns. If the stuffing box is not sealed after one or two turns on the bolts, back off until they are loose and add a stroke of grease (.5 oz) through the fitting slowly. Draw down the bolts until they are again just finger tight. Allow the mixer to run for a few minutes, then resume the tightening process.

Do not tighten the packing beyond the point required to seal the box. Check the box two or three times the first 24 hours of operation. If it starts to leak, an additional 1/4 turn should be sufficient to stop the leak in a minute or two.

After it has been installed and run in, the stuffing box should be periodically lubricated and inspected for leaks. Do not wait for a leak to start before lubricating the box. Longer packing life will be realized by preventing leaks through frequent lubrication.

After some experience with the amount of grease required, the lubrication interval can be shortened or lengthened. The unit can be lubricated while the unit is running or off. It is a good practice to lubricate after a prolonged shutdown.

When a leak does occur, the first impulse should be to lubricate the packing, not tightening the follower. The packing does not provide the seal, the lubrication does. Make sure the lantern ring has adequate lubricant. Adding lubricant will often stop the leak within a minute or so. If the box is still leaking after five minutes, the follower should be evenly tightened a quarter turn until the leak stops.

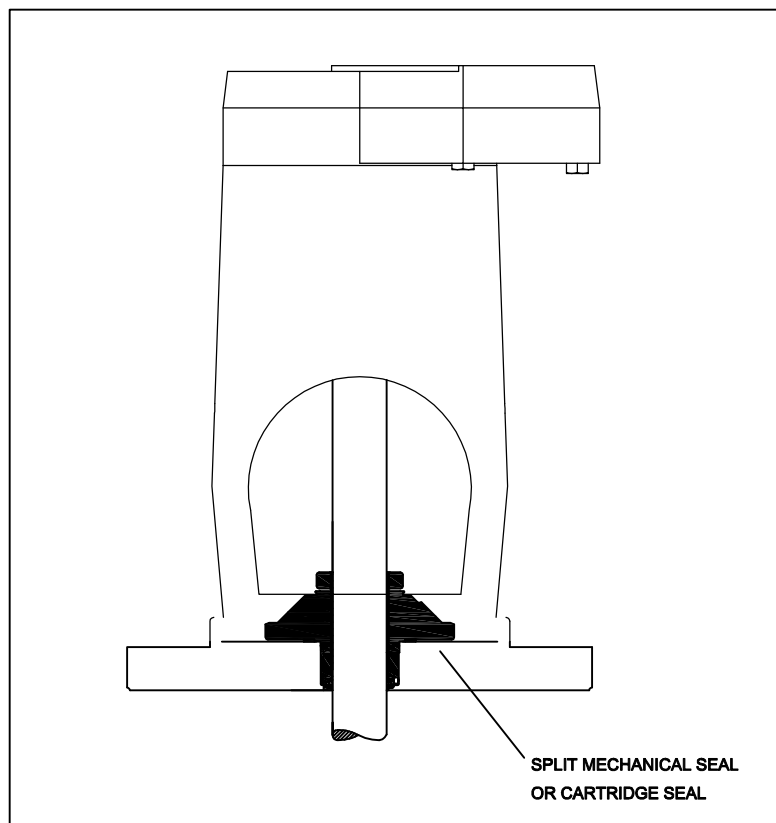

## MECHANICAL SEALS

In some closed tank or sealed applications, use of a mechanical seal may be necessary. If your mixer was supplied with a mechanical seal, the seal was packaged with a manual specific to that seal. Be sure to keep this manual and carefully follow all of the seal manufactures instructions for installation, operation and maintenance. It is common for split mechanical seals to drip. Do not use a split mechanical seal in applications where leakage is not permitted. Mechanical seals should be installed and maintained by a professional. In most cases, it is necessary to drain the tank or depressurize the seal before performing maintenance on the seal.

# Couplings & Flanges

## KEYLESS RIGID COUPLING

Keyless Rigid Couplings eliminate the need for shaft keys and keyways. Keyless rigid couplings will come with their own set of installation instructions specific to the size and style of coupling required for your mixer's design.

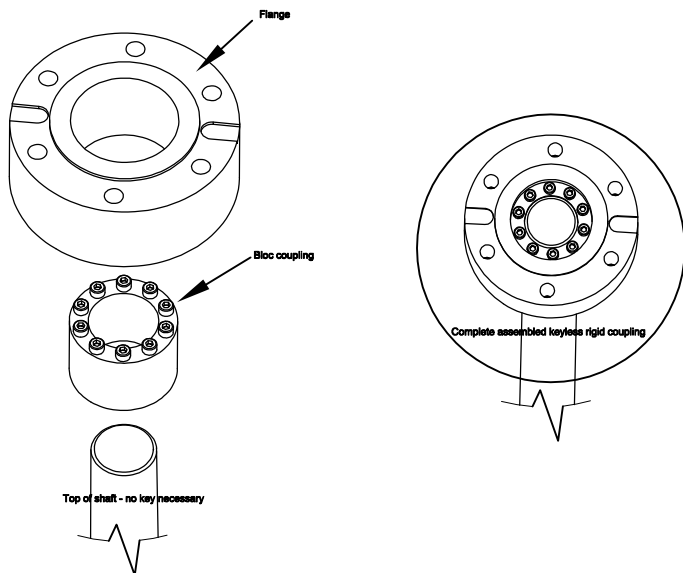

## MOUNTING FLANGES

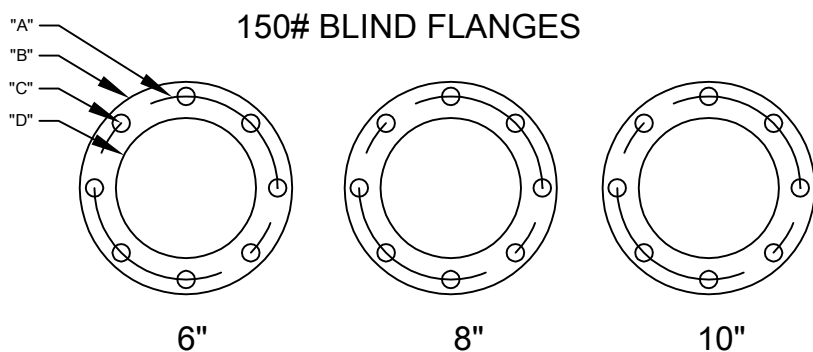

|     | "A"    | "B"    | "C"      | "D"    | "E"   |
|-----|--------|--------|----------|--------|-------|
| 6"  | 9.50"  | 11.00" | 8-0.88"  | 9.50"  | 1.00" |
| 8"  | 11.75" | 13.50" | 8-0.88"  | 11.75" | 1.12" |
| 10" | 14.25" | 16.00" | 12-1.00" | 14.25" | 1.19" |

Additional flange dimensions will be shown on your approval or assembly drawing.

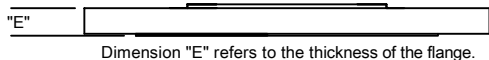

## REMOVABLE COUPLING

A removable coupling is typically used on a closed tank FRG with a seal or packing gland. It can be used in cases where the seal or gland needs maintenance but the mounting flange cannot be removed.

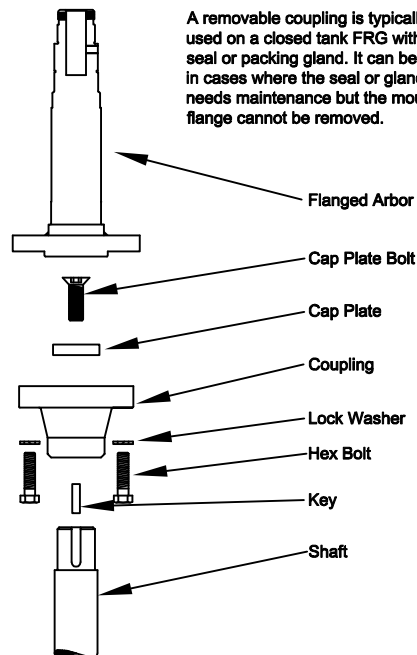

## RIGID COUPLING

A rigid shaft coupling is typically used on open tank FRG's with shaft lengths over 70". The rigid shaft coupling helps to stabilize long or heavy shafts.

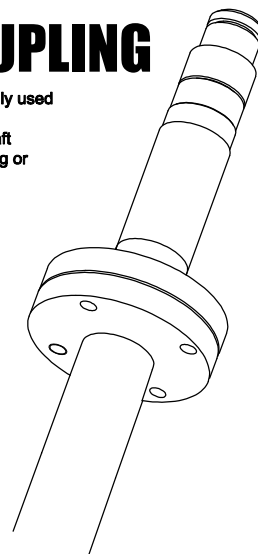

# MIXER POSITIONING - TOP ENTRY

T-Tank Diameter, D-Impeller Diameter. Dual impeller units - space upper 2D above lower or 2D min below surface of liquid level. Units that were not factory designed for angle mounting should not be angel mounted

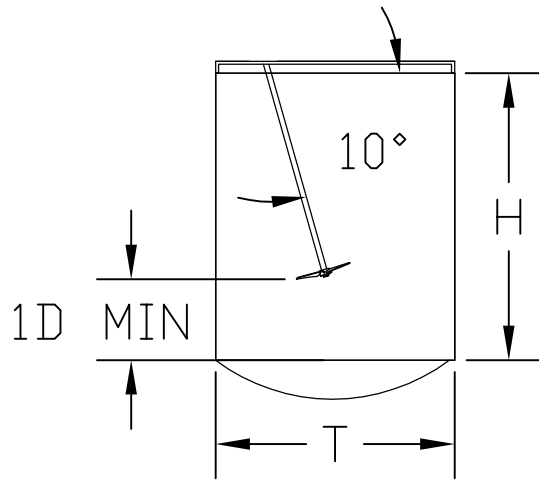
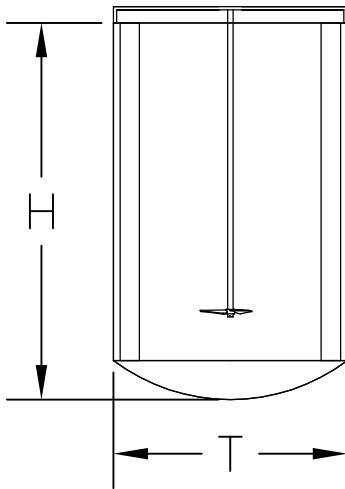
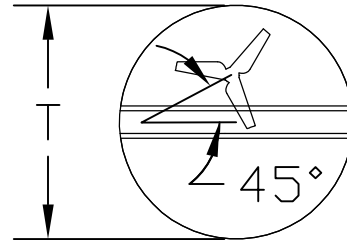
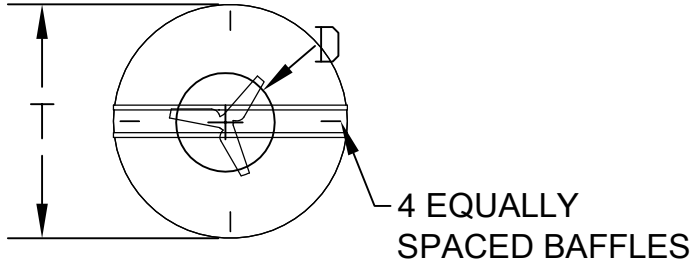

CYLINDRICAL TANK  
OFFSET ANGLE MOUNTED - NO BAFFLES

CYLINDRICAL TANK  
OFFSET ANGLE MOUNTED - NO BAFFLES

# MIXER POSITIONING - SIDE ENTRY

| SQUARE TANK - OFFSET | ROUND TANK - OFFSET | ROUND TANK - ANGLED |
|----------------------|---------------------|---------------------|
|                      |                     |                     |

# DEACTIVATION & STORAGE

## DEACTIVATION

SHORT TERM SHUTDOWN - Units may be deactivated and left on line for up to four months without special precautions.

LONG TERM SHUTDOWN - If the unit is to be deactivated or stored for more than four months after any period of operation:

1. Indoor dry storage is recommended for all inactive units. Deactivated units stored outdoors should be protected from the weather. It is most important to keep the unit dry and in a temperature controlled area.
2. Mixer shafts should be removed and coated with Cosmoline or suitable preservative (even stainless steel shafts should be coated where they come into contact with steel or banding straps). Make sure the shafts are properly supported to prevent bending. It is good to rotate the shafts periodically to keep them from settling in one position which can cause them to bend. When storing carbon steel parts outdoors, apply suitable grease or rust preventative to all parts. Turbine parts should also be coated with preservative, especially the bore of the turbine hub.
3. Motors should be stored in a cool, dry environment: the motor shaft should be rotated once each month.
4. Inspect stored or inactive units at 90 day intervals. Re-spray with rust preventative or add rust inhibitor at least once every six months as required.

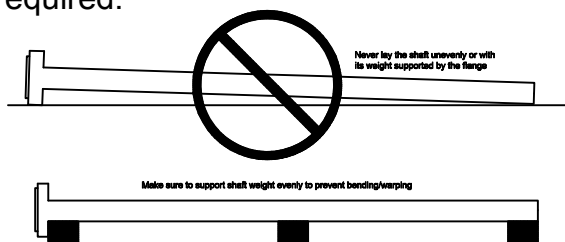

## INSUFFICIENT MIXING

If you're not getting the desired level of mixing from your mixer, first check the following items: your impeller or propeller is installed properly and is rotating in the correct direction. Make sure the impeller or propeller is on the shaft. Make sure the shaft is securely connected to the mixer and is rotating at the designed RPM. You might need to increase the size or number of impellers/propellers. If this is the case, you may also need to increase the horse power. Adding tank baffles or angle mounting the mixer might also help to increase mixing. Call Cleveland Mixer with the process data and tank dimensions for further assistance.

# TROUBLE SHOOTING

| PROBLEM WITH THE REDUCER         |  | POSSIBLE CAUSES   | SUGGESTED REMEDY   |
|----------------------------------|--|---|--|
| <b>OVERLOAD</b>                  | running hot, motor drawing high amps                                   | load exceeds the capacity of the motor  | reduce load capacity<br>reducer viscosity<br>reducer impeller diameter<br>increase horse power                                 |
|                                  | lack of lubrication  | leakage, burnt grease   | check lubrication level and adjust to recommended level  |
|                                  |  | wrong lubrication   | flush out and refill with correct lubricant as recommended   |
| <b>RUNS NOISY</b>                | shaking / vibration<br>loose hardware                                  | mounting structure<br>loose hold down bolts   | inspect mounting of reducer<br>tighten loose bolts.<br>reinforce mounting structure  |
|                                  | bearing failure<br>gear failure<br>shaft vibrating                     | overload<br>lack of lubrication<br>bent shaft<br>running at within critical-speed range | reduce load capacity<br>reducer viscosity<br>reducer impeller diameter<br>increase horse power<br>use vfd<br>check lubrication |
|                                  | impeller / prop connecting w/ tank                                     | mounting  | change mounting position   |
| <b>OUTPUT SHAFT DOESN'T TURN</b> | internal parts are broken<br>unit running hot, loud, pulling high amps | overloading of a reducer<br>can cause damage  | replace broken parts. Check rated capacity   |
|                                  |  | key missing or sheared off in input shaft   | replace key  |
|                                  |  | coupling loose or disconnected  | properly align reducer and coupling. Tighten coupling.   |
| <b>LUBE LEAKAGE</b>              | worn seals<br>unit leaking oil   | caused by dirt or grit entering seal  | replace seals  |
|                                  |  | overfilled reducer  | check lubricant level and adjust to recommended level.   |
|                                  |  | Improper mounting position, such wall or ceiling mount<br>horizontal reducer            | clean or replace, being sure to prevent any dirt from falling into the reducer   |
|                                  |  |   | check mounting position  |



# PARTS BREAKDOWN - OPEN TANK FRG - Gear Drive

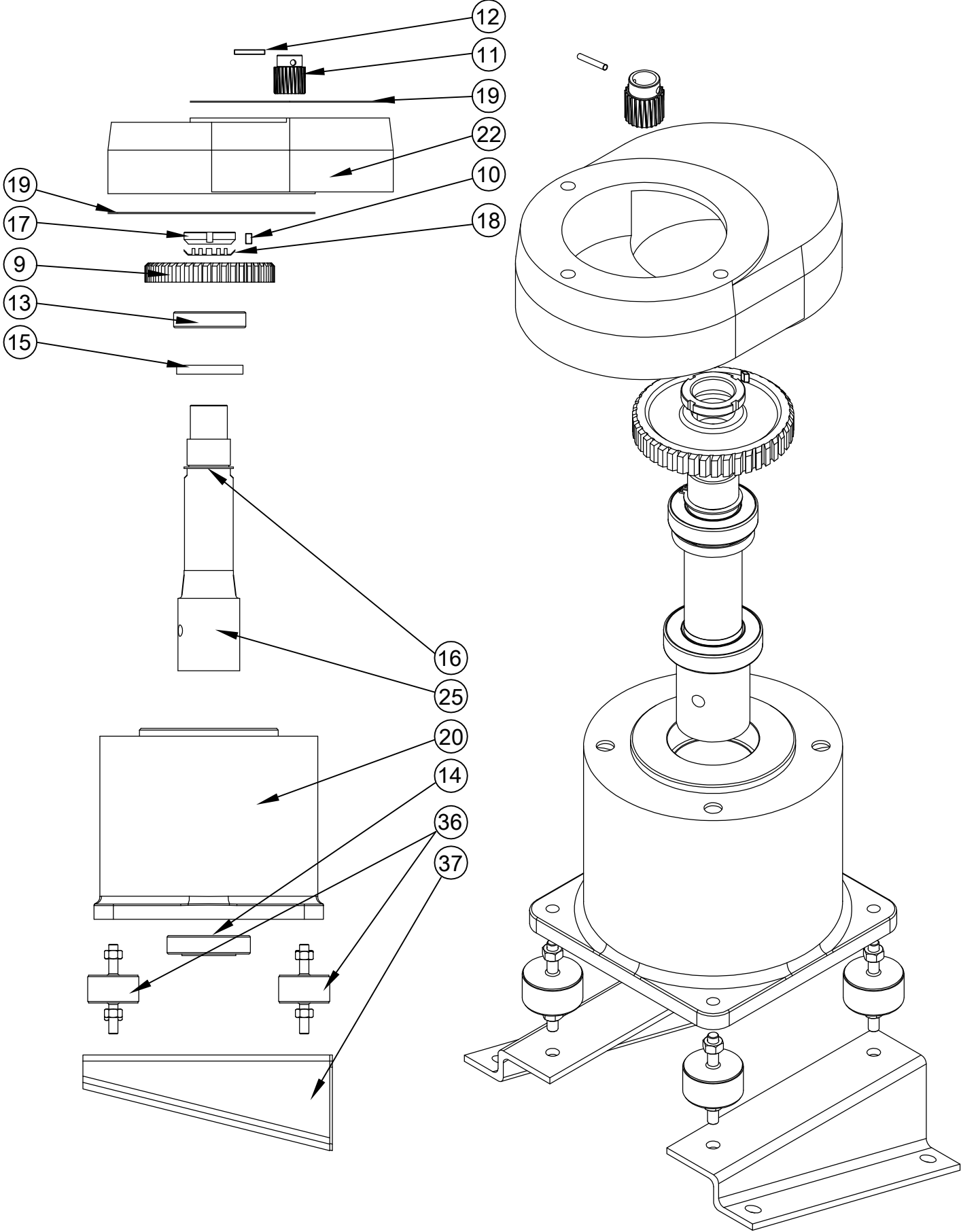

# PARTS BREAKDOWN - CLOSED TANK FRG - Gear Drive

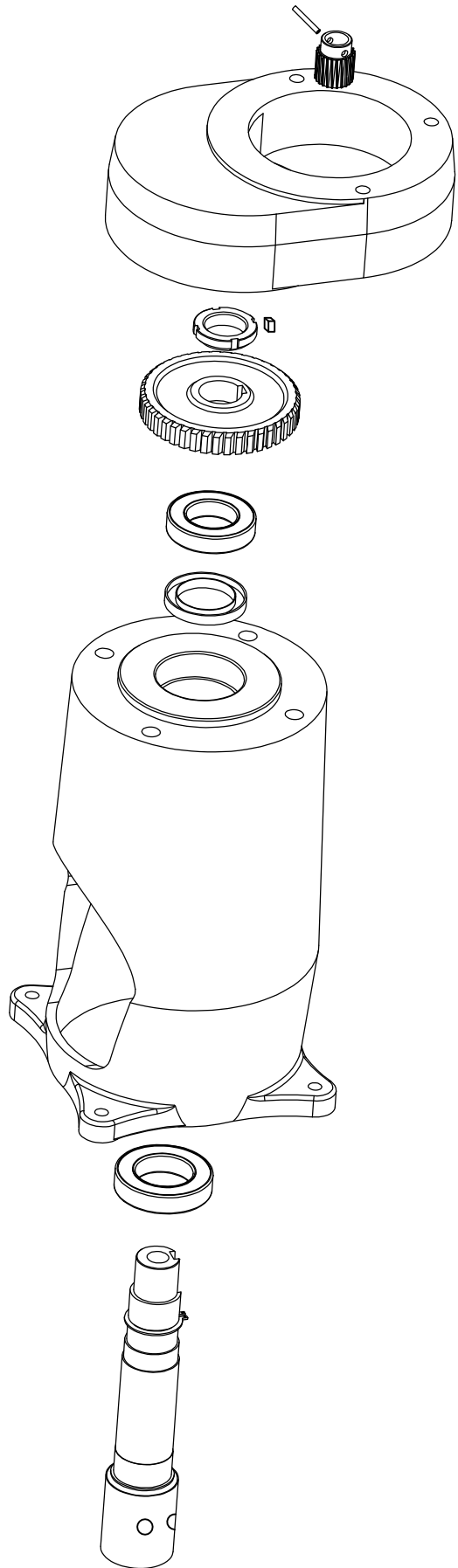
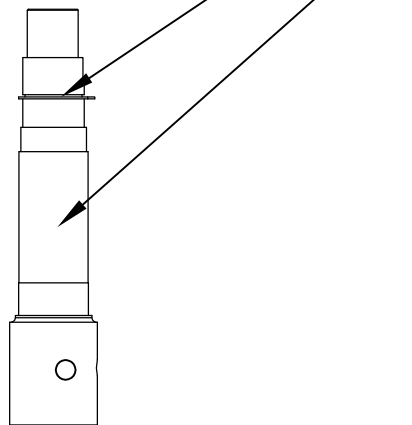
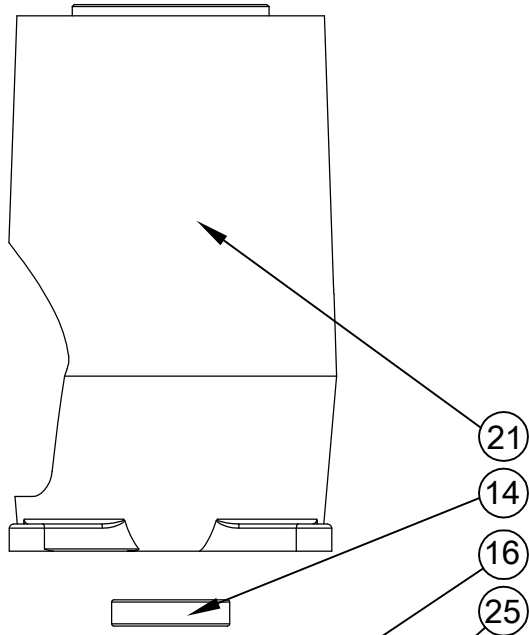
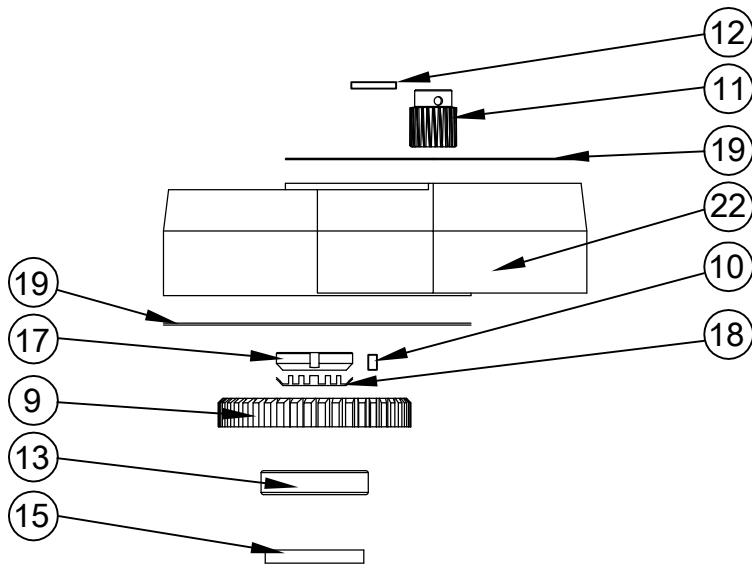

# PARTS BREAKDOWN - OPEN TANK FRH - Direct Drive

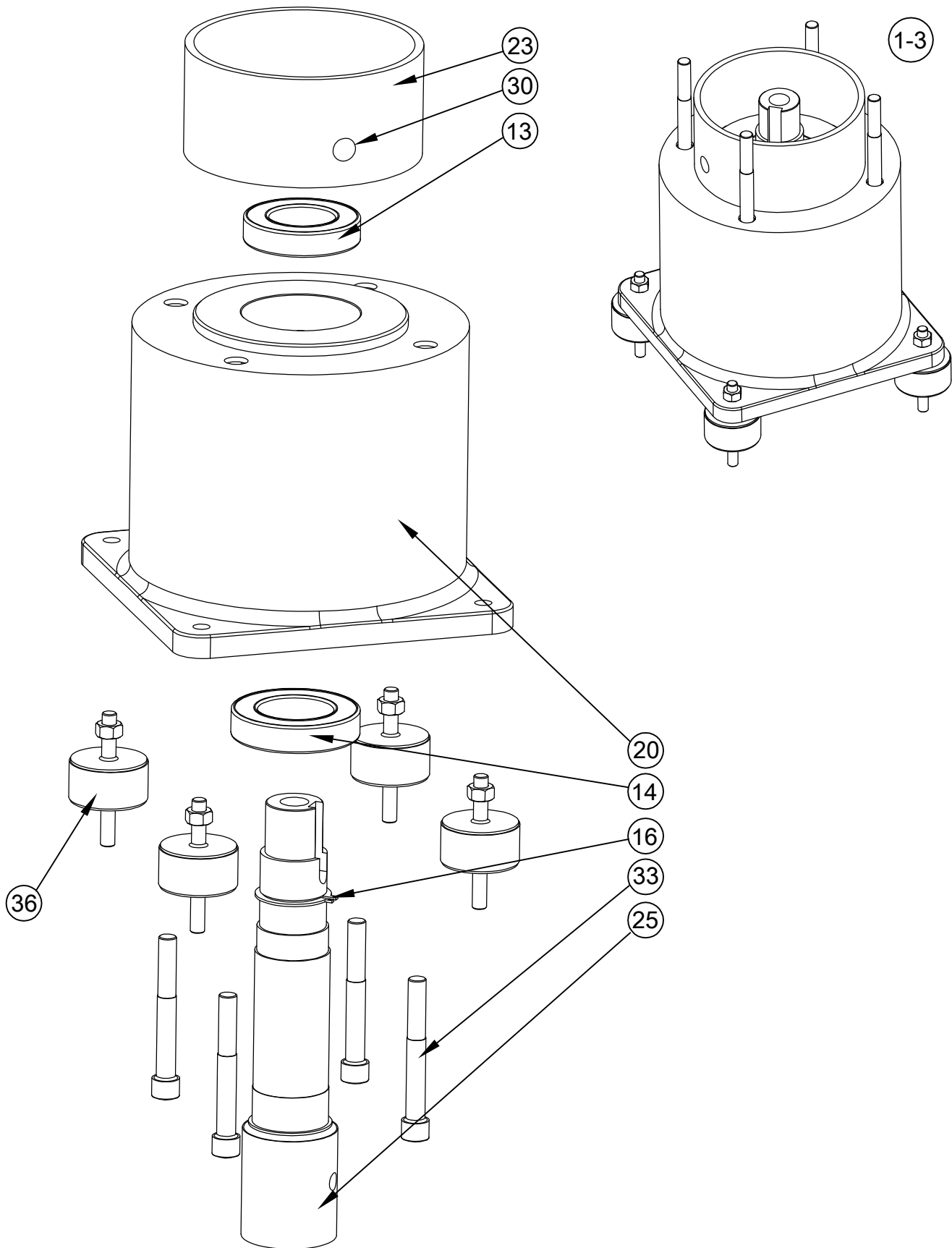

# PARTS BREAKDOWN - CLOSED TANK FRH - Direct Drive

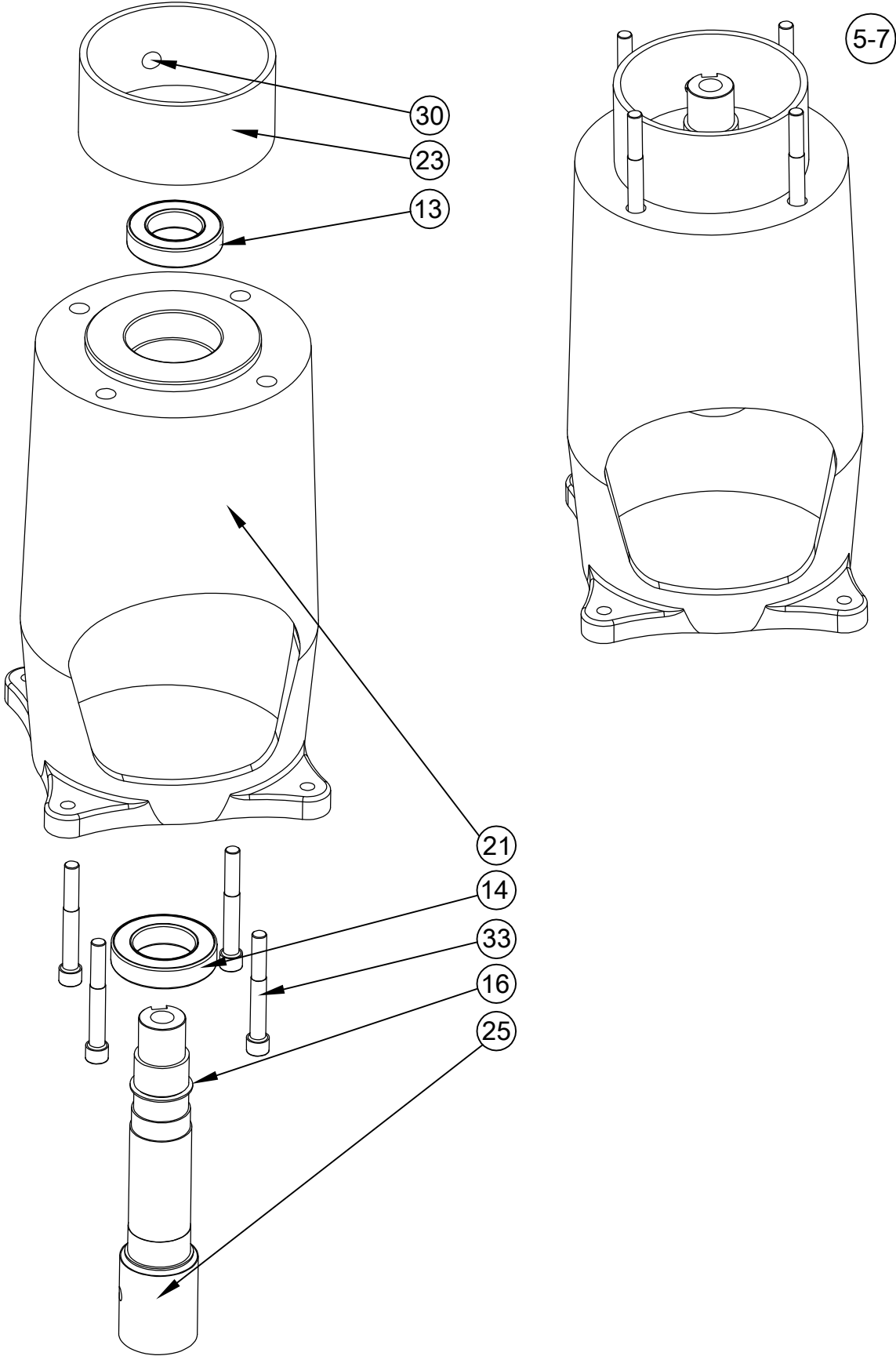

# PARTS BREAKDOWN - CLOSED TANK FRG

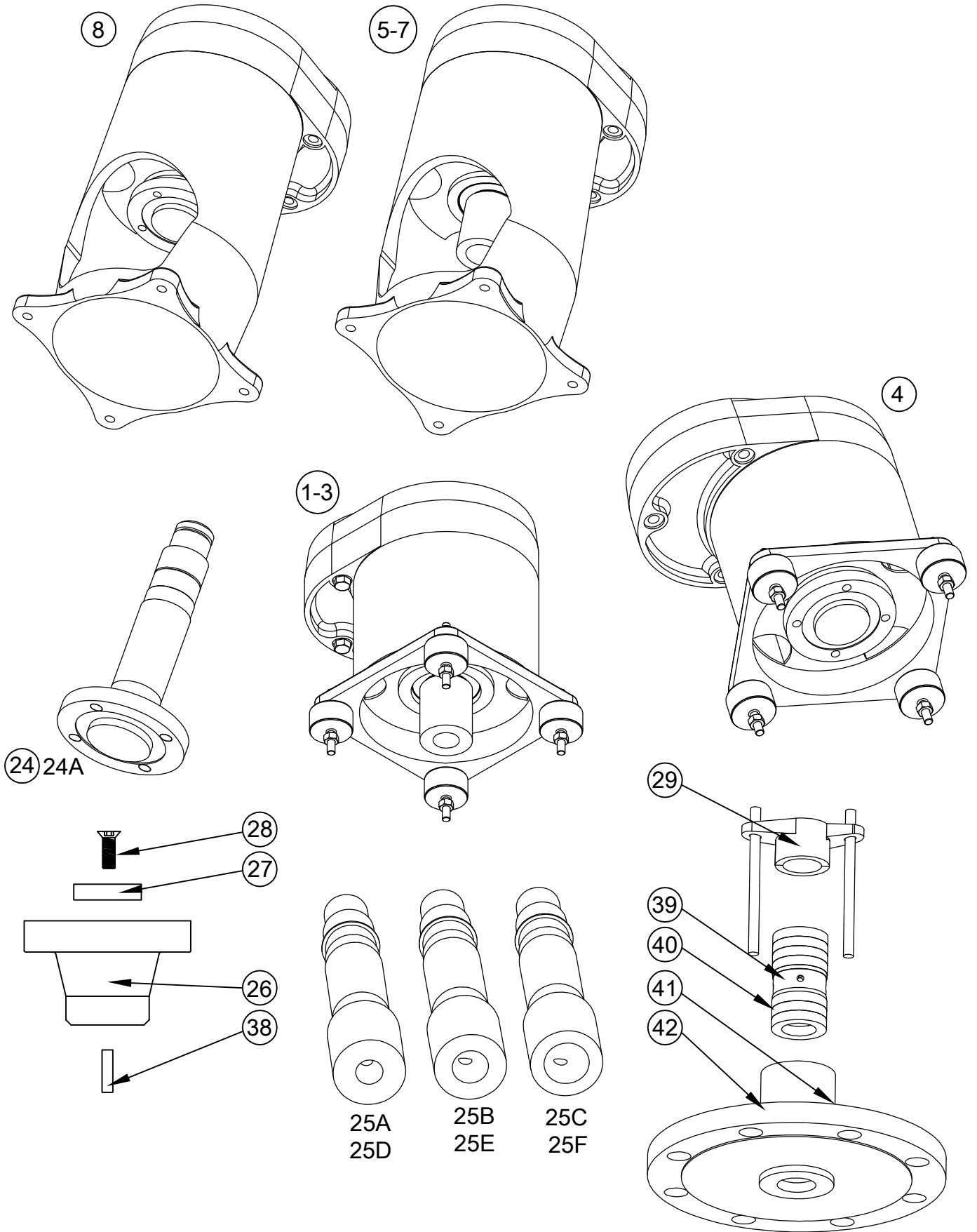

# FRG MODELS PARTS LIST

| #    | Part Description                                  | Part Number                  | #  | Part Description                              | Part Number     |
|------|---|------------------------------|----|---|-----------------|
| 1    | Gear Drive .75" bore - Open Tank                  | FRG-.75 / FRH-.75 direct     | 28 | Cap Plate Bolt - FHSCS 5/16-18 x 1.25         | 330510-5/16-125 |
| 2    | Gear Drive 1" bore - Open Tank                    | FRG-1.0 / FRH-1.0 direct     | 28 | Cap Plate Bolt - FHSCS 3/8-16 x 1.25          | 330510-3/8-125  |
| 3    | Gear Drive 1.25" bore - Open Tank                 | FRG-1.25 / FRH-1.25 direct   | 29 | Split Follower - .75" shaft                   | 330450          |
| 4    | Gear Drive Flange Coupling - Open Tank            | FRG-CPG                      | 29 | Split Follower - 1.00" shaft                  | 330451          |
| 5    | Gear Drive .75" bore - Closed Tank                | FRG-.75C / FRH-.75C direct   | 29 | Split Follower - 1.25" shaft                  | 330452          |
| 6    | Gear Drive 1" bore - Closed Tank                  | FRG-1.0C / FRH-1.0C direct   | 30 | Button Plug                                   | 329388P01       |
| 7    | Gear Drive 1.25" bore - Closed Tank               | FRG-1.25C / FRH-1.25C direct | 31 | 3/8-24 x 1/2 set screw - zinc, qty 2          | 320160P47       |
| 8    | Gear Drive Flange Coupling - Closed Tank          | FRG-CPGC                     | 32 | 1/4-28 x 3/8 set screw - zinc, qty 2          | 320160P29       |
| **   | Rebuild Kit - FRG closed/open                     | KIT2                         | 33 | 3/8-16 x 3.25 SHCS - zinc, qty 4              | 320217P134      |
| **   | Maintenance Kit - FRG closed/open                 | KIT4                         | 34 | 3/8-16 x 1.00 SHCS - zinc, qty 4              | 320217P1        |
| 9*   | Gear  | 310151                       | 35 | 3/8-16 x 2.5" HHCS - zinc, qty 3              | 320032P43       |
| 10*  | Gear Key  | 310268                       | 35 | 3/8" split lock washer                        | 320050P3        |
| 11** | Pinion  | 313828                       | 36 | Flex Bolt Mount Set - qty 4                   | 322646P1-5      |
| 12** | Drive Pin   | 320958P1                     | 37 | Angle Riser - Left                            | 316314L         |
| 13** | Upper Bearing                                     | 320840P1                     | 37 | Angle Riser - Right                           | 316314R         |
| 14** | Lower Bearing                                     | 322852P1                     | 38 | Key - 1.00" Shaft                             | 330443          |
| 15** | Oil Seal  | 330289                       | 38 | Key - 1.25" Shaft                             | 330444          |
| 16** | Retaining Ring                                    | 330449                       | 38 | Key - 1.50" Shaft                             | 330445          |
| 17** | Lock Nut  | 315385                       | 39 | Lantern Ring - .75" shaft                     | A-8456          |
| 18** | Lock Washer                                       | 329387P01                    | 39 | Lantern Ring - 1.00" shaft                    | A-8457          |
| 19** | Gasket - Qty 2                                    | 314459                       | 39 | Lantern Ring - 1.25" shaft                    | A-8447          |
| 20   | Square Base - open tank                           | 315607                       | 39 | Lantern Ring - 1.50" shaft                    | A-8448          |
| 21   | Tall Stool - closed tank                          | 315617                       | 40 | Teflon Packing Rings / HPSB 7 / LPSB 2        | 901300          |
| 22   | Gear Case   | 311084                       | 41 | Grease Fitting - 1/8"                         | 320145P1        |
| 23   | Spacer - direct drive                             | 315516                       | 41 | Grease Reliefe - 1/8"                         | 320145P1        |
| 24   | Flanged Arbor - Steel                             | 315625                       | 42 | Flange - 6" 150#                              |                 |
| 24A  | Flanged Arbor - stainless steel                   | 315625S                      | 42 | Flange - 8" 150#                              |                 |
| 25A  | Arbor - .75" bore, steel                          | 315618-6                     | 42 | Flange - 10" 150#                             |                 |
| 25B  | Arbor - 1.00" bore, steel                         | 315618-4                     |    | Teflon shut off - .75" shaft, side entry      | B-17077         |
| 25C  | Arbor - 1.25" bore, steel                         | 315618-5                     |    | Teflon shut off - 1.00" shaft, side entry     | B-16151         |
| 25D  | Arbor - .75" bore, stainless steel                | 315618-6S                    |    | Teflon shut off - 1.25" shaft, side entry     | B-16293         |
| 25E  | Arbor - 1.00" bore, stainless steel               | 315618-4S                    |    | 10' line cord - 1PH, 115V                     | 311037-3        |
| 25F  | Arbor - 1.25" bore, stainless steel               | 315618-5S                    |    | Toggle switch - 1PH, 115V                     | 330068          |
| 26   | Removable Coupling - 1.00" shaft, steel           | 330440                       |    | Needle Valve - .25NPT, .5-1HP                 | 330127-2        |
| 26   | Removable Coupling - 1.25" shaft, steel           | 330441                       |    | Needle Valve - .50NPT, 2HP                    | 330127-12       |
| 26   | Removable Coupling - 1.50" shaft, steel           | 330442                       |    | Motor - .25HP, 1750RPM, 1/60/115/230 TEFC 56C | BALKL3403       |
| 26   | Removable Coupling - 1.00" shaft, stainless steel | 330440Z                      |    | Motor - .33HP, 1750RPM, 1/60/115/230 TEFC 56C | BALVL3501       |
| 26   | Removable Coupling - 1.25" shaft, stainless steel | 330441Z                      |    | Motor - .50HP, 1750RPM, 1/60/115/230 TEFC 56C | BALVL3504       |
| 26   | Removable Coupling - 1.50" shaft, stainless steel | 330442Z                      |    | Motor - .75HP, 1750RPM, 1/60/115/230 TEFC 56C | BALVL3507       |
| 27   | Cap Plate - 1.00" shaft                           | 18362-16337521C              |    | Motor - 1HP, 1750RPM, 1/60/115/230 TEFC 56C   | BALVL3510       |
| 27   | Cap Plate - 1.25" shaft                           | 18362-16337525C              |    | Motor - 1.5HP, 1750RPM, 1/60/115/230 TEFC 56C | BALVL3514       |
| 27   | Cap Plate - 1.50" shaft                           | 18362-16337530C              |    | Motor - .25HP, 1750RPM, 3/60/230/460 TEFC 56C | BALKM3455       |

# FRG MODELS PARTS LIST

Additional sizes available

| # | Part Description                              | Part Number | # | Propeller - direct drive            | Part Number |
|---|---|-------------|---|-------------------------------------|-------------|
|   | Motor - .33HP, 1750RPM, 3/60/230/460 TEFC 56C | BALVM3534   |   | Prop - 3.5" dia. .75" bore, 316ss   | 313850-BBZ6 |
|   | Motor - .50HP, 1750RPM, 3/60/230/460 TEFC 56C | BALVM3538   |   | Prop - 4.00" dia. .75" bore, 316ss  | 313850-CCZ6 |
|   | Motor - .75HP, 1750RPM, 3/60/230/460 TEFC 56C | BALVM3542   |   | Prop - 4.00" dia. 1.00" bore, 316ss | 313850-CCZ8 |
|   | Motor - 1HP, 1750RPM, 3/60/230/460 TEFC 56C   | BALVM3546   |   | Prop - 4.50" dia. .75" bore, 316ss  | 313850-DDZ6 |
|   | Motor - 1.5HP, 1750RPM, 3/60/230/460 TEFC 56C | BALVM3554   |   | Prop - 4.50" dia. 1.00" bore, 316ss | 313850-DDZ8 |
|   | Motor - 2HP, 1750RPM, 3/60/230/460 TEFC 56C   | BALVM3558   |   | Prop - 5.00" dia. .75" bore, 316ss  | 313850-EEZ6 |
|   | Motor - 3HP, 1750RPM, 3/60/230/460 TEFC 56C   | BALVM3561   |   | Prop - 5.00" dia. 1.00" bore, 316ss | 313850-EEZ8 |
|   | Air Motor - .5 - 1HP, 1800RPM, 56C, Exp Proof | 313866-2    |   | Prop - 6.00" dia. 1.00" bore, 316ss | 313850-GGZ8 |
|   | Air Motor - 2HP, 1800RPM, 56C, Exp Proof      | 313866-3    |   | Prop - 7.00" dia. 1.00" bore, 316ss | 313850-JJZ8 |

XX = shaft working length

| Part Description   | Part Number |
|--|-------------|
| Mixer Shaft - Fixed Entry, Open Tank, Vertical - 316ss .75" diameter, adjustable length              | 340069-XXZ  |
| Mixer Shaft - Fixed Entry, Open Tank, Vertical - 316ss 1.00" diameter, adjustable length             | 315999-XXZ  |
| Mixer Shaft - Fixed Entry, Open Tank, Vertical - 316ss 1.25" diameter, adjustable length             | 315837-XXZ  |
| Mixer Shaft - Fixed Entry, Open Tank, Angle Mounted - 316ss .75" diameter, adjustable length         | 340070-XXZ  |
| Mixer Shaft - Fixed Entry, Open Tank, Angle Mounted - 316ss 1.00" diameter, adjustable length        | 316347-XXZ  |
| Mixer Shaft - Fixed Entry, Open Tank, Angle Mounted - 316ss 1.25" diameter, adjustable length        | 316348-XXZ  |
| Mixer Shaft - Fixed Entry, Closed Tank - 316ss .75" diameter, adjustable length                      | 340067-XXZ  |
| Mixer Shaft - Fixed Entry, Closed Tank - 316ss 1.00" diameter, adjustable length                     | 316002-XXZ  |
| Mixer Shaft - Fixed Entry, Closed Tank - 316ss 1.25" diameter, adjustable length                     | 315839-XXZ  |
| Mixer Shaft - Fixed Entry, Closed Tank, Removable Coupling - 316ss 1.00" diameter, adjustable length | 330446-XXZ  |
| Mixer Shaft - Fixed Entry, Closed Tank, Removable Coupling - 316ss 1.25" diameter, adjustable length | 330447-XXZ  |
| Mixer Shaft - Fixed Entry, Closed Tank, Removable Coupling - 316ss 1.50" diameter, adjustable length | 330448-XXZ  |

\*\*All Cleveland Mixer shafts come in pump shaft quality 316ss unless otherwise specified

| XTF-3 Impellers |            |            |            |            |
|-----------------|------------|------------|------------|------------|
| Dia.            | .75" Bore  | 1.00" Bore | 1.25" Bore | 1.50" Bore |
| 8               | 609-101-08 | 609-102-08 | 609-103-08 | 609-104-08 |
| 9               | 609-101-09 | 609-102-09 | 609-103-09 | 609-104-09 |
| 10              | 609-101-10 | 609-102-10 | 609-103-10 | 609-104-10 |
| 11              | 609-101-11 | 609-102-11 | 609-103-11 | 609-104-11 |
| 12              | 609-101-12 | 609-102-12 | 609-103-12 | 609-104-12 |
| 13              | 609-101-13 | 609-102-13 | 609-103-13 | 609-104-13 |
| 14              | 609-101-14 | 609-102-14 | 609-103-14 | 609-104-14 |
| 15              | 609-101-15 | 609-102-15 | 609-103-15 | 609-104-15 |
| 16              | 609-101-16 | 609-102-16 | 609-103-16 | 609-104-16 |
| 17              | 609-101-17 | 609-102-17 | 609-103-17 | 609-104-17 |
| 18              | 609-101-18 | 609-102-18 | 609-103-18 | 609-104-18 |
| 19              | 609-101-19 | 609-102-19 | 609-103-19 | 609-104-19 |
| 20              | 609-101-20 | 609-102-20 | 609-103-20 | 609-104-20 |

With Stabilizer Fins = .75" 609-210- / 1.00" 609-211- / 1.25" 609-212- / 1.50" 609-213-

\*\*All impellers and propellers come standard in 316ss unless otherwise specified